

●FUNCTIONS

Functions of Keys(Fig.2):

mm/in: Metric system/British system shifter

OFF/ON: Display on/off.

P-: Negative preset.

P+: Positive preset.

ZERO\ABS Relative/Absolute measuring shifter.

RESET: Preset/Set to zero for display.

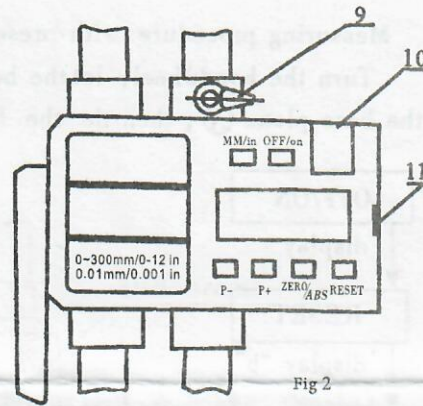

Fig 2

Features: Having function of memorizing preset value before taking away the battery.

●APPLICATIONS

Measuring Methods:

Measuring without preset value(Fig.3)

Let the bottom plane of the scriber contact with the base plane (A) than do the following operations:

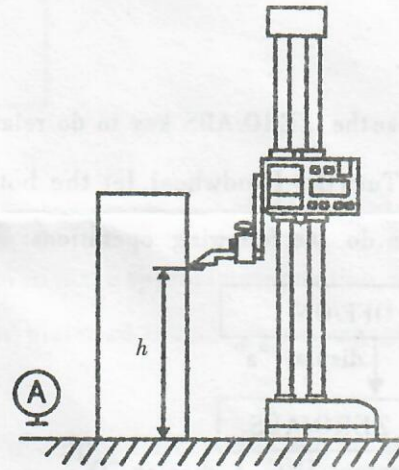
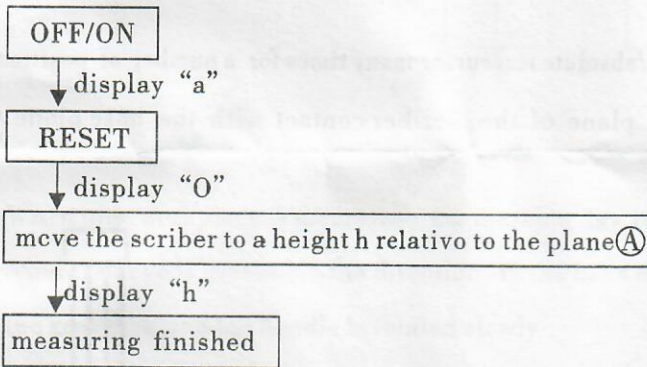

Fig 3

● Measuring with preset value:

Preset Procedure is as follows

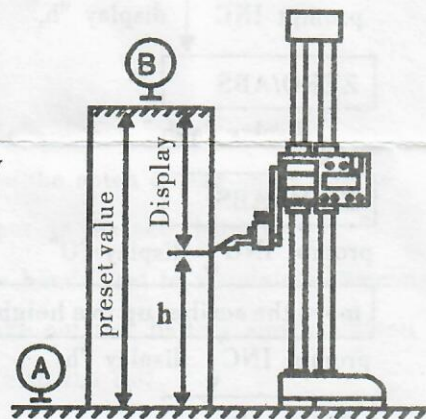
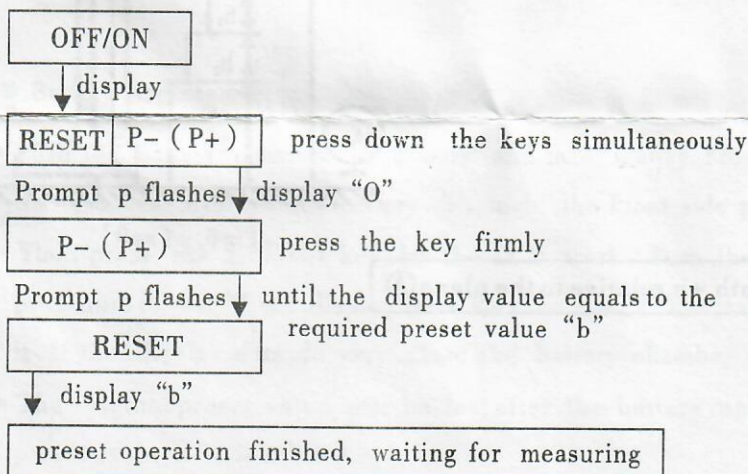

Fig4 (P-)

Measuring procedure with preset value "b" (Fig4, 5)

Turn the handwheel, let the bottom plane of the scriber contact with the base plane (A), then do the following operations:

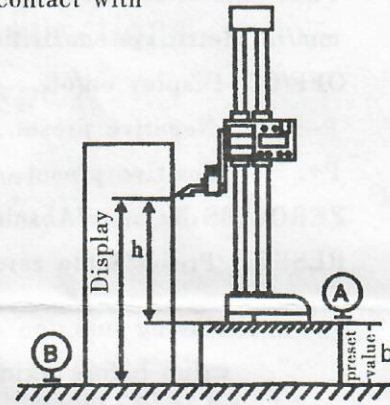
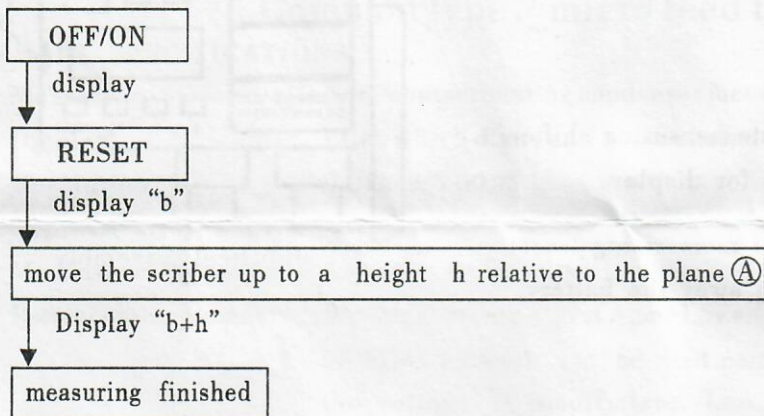

Fig5 (P+)

Method of deleting the preset value: When the preset value is not needed, use the preset procedure to preset the value equal to 0.

- Use the ZERO/ABS key to do relative/absolute measuring many times for a number of positions:

Turn the handwheel, let the bottom plane of the scriber contact with the base plane (A), then do the following operations:

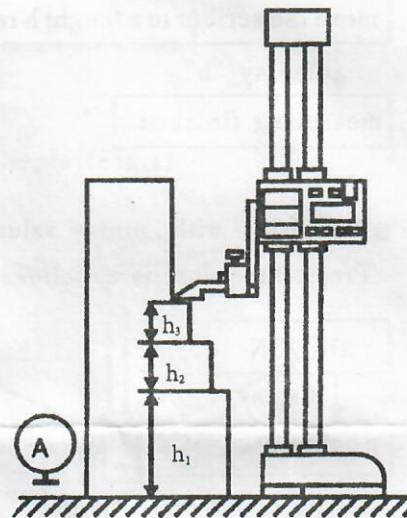
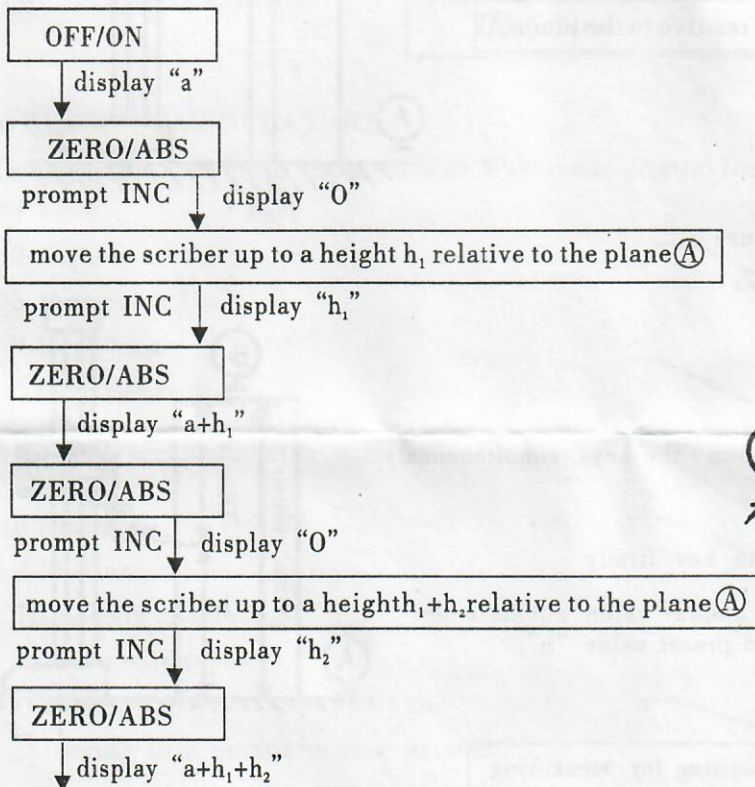
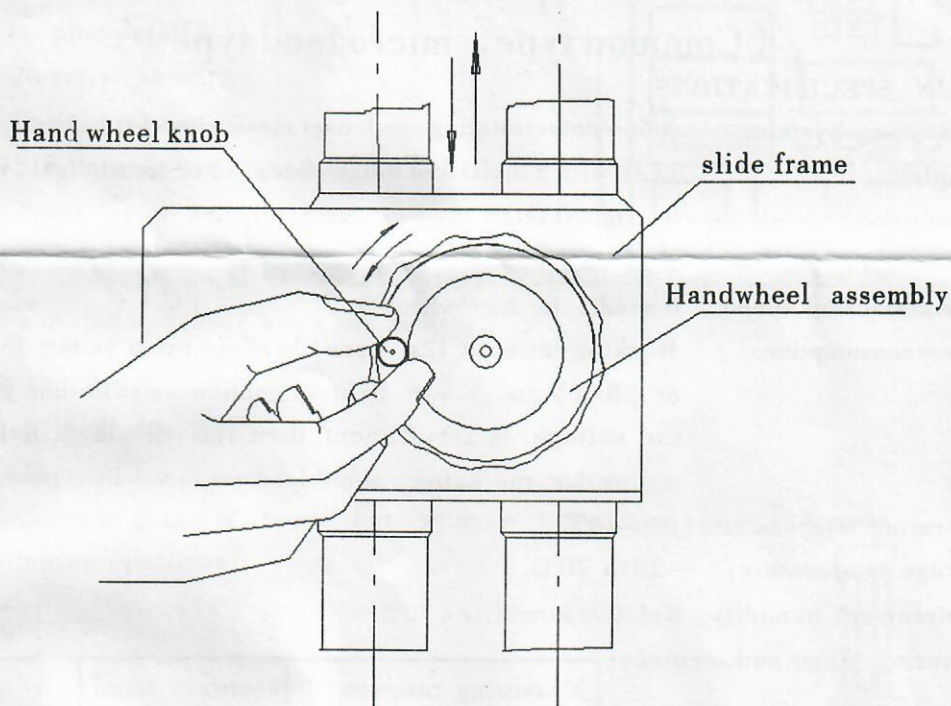

Fig6 (a=0)

● The use of hand wheel adjustment device (micro feed type)



- When the workpiece is measured, the marking jaw is moved to the approximate position, and the handle sleeve is pressed in the direction of the back cover plate, so that the gear is engaged with the gear disk, and the handle is rotated slowly.
- The measurement is completed, will handle away from the rear direction is pulled out, the gear and the gear disk can be disengaged, a wide range of mobile ruler frame.

● Battery Replacement:

- Push the battery chamber lid up and take it away. From the notch on the upper side of the chamber pick out the battery. Through the front side put in the new battery.
- Then press the OFF/ON key, let the LCD work, Turn the handwheel to simulate measuring procedure to see if the display data vary or not. If not, take out the battery and re-install it. If the display data do vary, close the battery chamber with the lid.
- The original preset value will be lost after the battery replacement operation, It should be preset again if it is needed.

Two-column type Height Gauge with Electronic Digital Display

Main Technical Specifications and Functions

(Common type, micro feed type)

●MAIN SPECIFICATIONS

- Measuring System: Non-contact rotating condenser measuring system
- Display: LCD, with 5 digits and a sign character or 8mm height
- Resolution: 0.01mm/0.001"
- Repeatability precision: 0.01mm/0.001"
- Max.measuring speed: 6π rad/s for handwheel.
- Power consumption: Working current $< 12\mu A$, one 1.5v silver oxide battery (SR44W or SR44 battery) can be used continuously for one year. If the voltage is insufficient, then the display will flash. It means that the battery should be replaced by a new one.

Operating temperature: 0 to 40°C.

Storage temperature: -20 to 70°C.

Environment humidity: Relative humidity $< 80\%$

Measuring range and accuracy:

Measuring range (mm)	accuracy (mm)
0~200	± 0.03
> 200~300	± 0.04
> 300~600	± 0.05

●TYPES NOMENCLATURE

Two-column type Height Gauge with Electronic Digital Display(Fig.1)

- 1.Base
- 2.Scriber
- 3.Measuring Jaw
- 4.Slide frame
- 5.Cylinder rack
- 6.Beam
- 7.Handwheel
- 8.Display
- 9.Slider clamp
- 10.Battery chamber lid
- 11.Data output port:
Measuring data output port for linking to a computer or a printer.

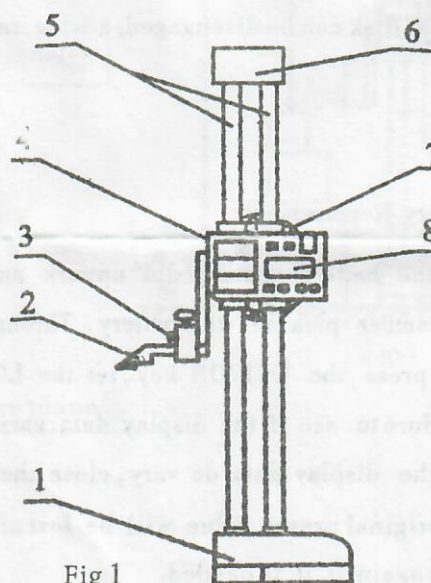

Fig 1