

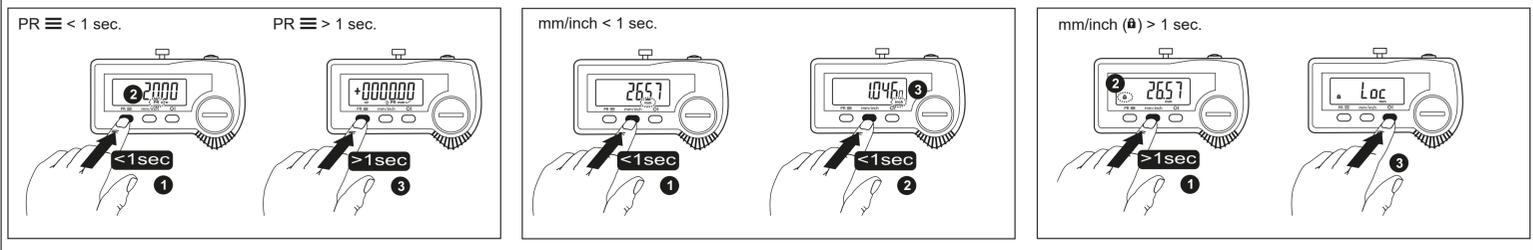

8.4 Direkte Tastenfunktionen 8.4 Direct button functions 8.4 Fonctions de touches directes 8.4 Funciones de teclas directas 8.4 Funzioni dei tasti diretti 8.4 直接键功能

Table with 6 columns and 2 rows detailing button functions for PR, mm/inch, and IO buttons under various time constraints (< 1 Sec, > 1 Sec).



8.5 MENÜ 8.5 MENU 8.5 MENU 8.5 MENÜ 8.5 MENU 8.5 菜单键包含的功能

Table with 6 columns and 2 rows detailing menu navigation functions for PR, mm/inch, and IO buttons.

Table with 6 columns and 2 rows detailing menu functions for PR, CH 01, ECO 0, OFF 8, and FA-SET buttons.

8.5.3 Strukturdiagramm der Menüfunktionen 8.5.3 Structure diagram of menu functions 8.5.3 Organigramme des fonctions de menu 8.5.3 Diagrama estructurado de las funciones del menú 8.5.3 Diagramma di struttura delle funzioni di menu 8.5.3 菜单功能结构图

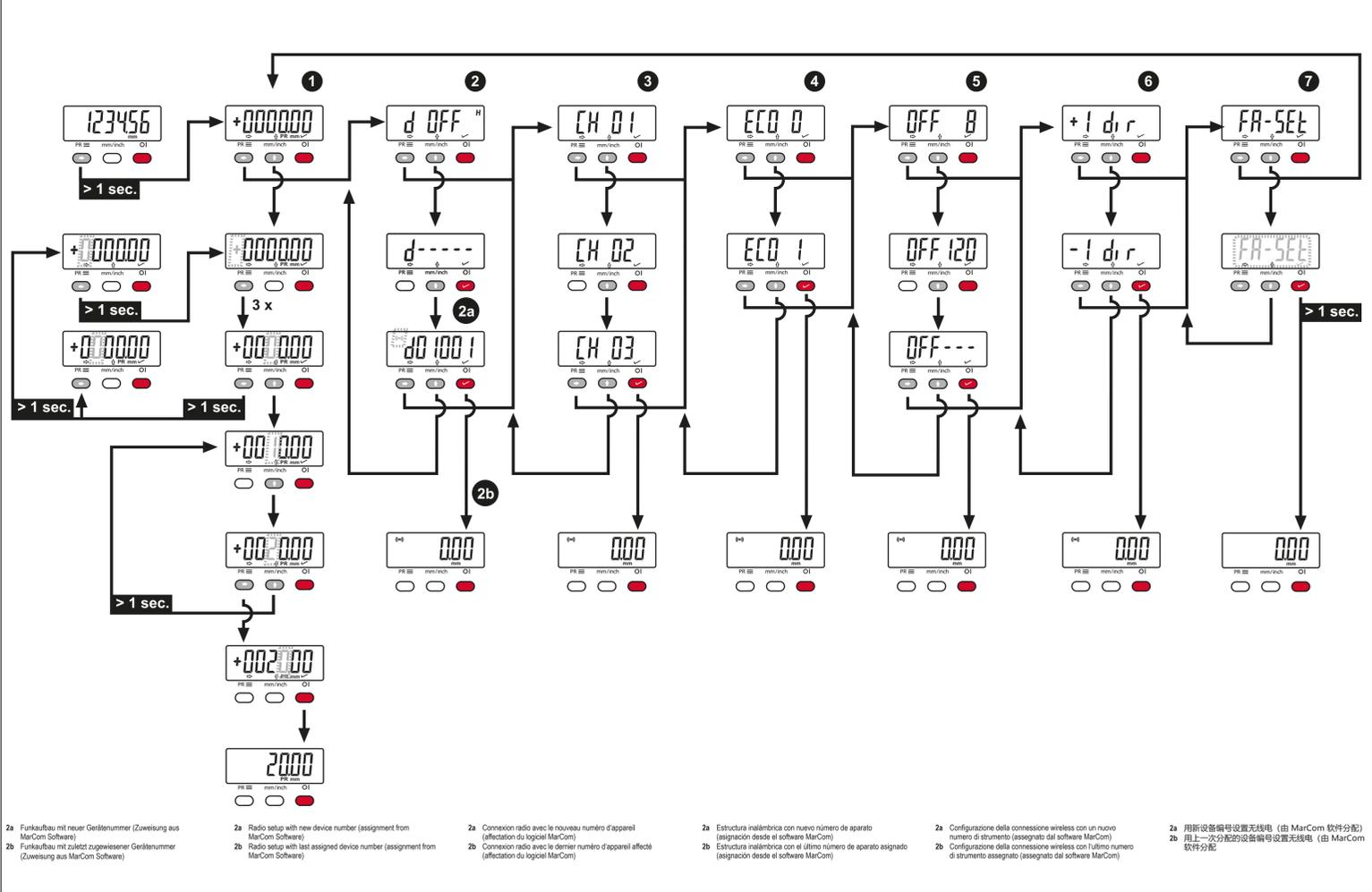

9. Displaymeldungen 9. Display Messages 9. Affichage de message 9. Mensajes de pantalla 9. Note sullo smaltimento 9. 提示信息

Table with 6 columns and 2 rows detailing display messages for Loc, Battery, and no dAt errors, including illustrations of the device display.

Table with 6 columns and 2 rows detailing confirmation of traceability in various languages.

Table with 6 columns and 2 rows detailing disposal instructions for the device, including environmental and recycling information.

Table with 6 columns and 2 rows detailing EU conformity declarations in various languages.

Mahr logo and product information for MarCal 18 EWRI, including contact details for Mahr GmbH and a CE mark.

Bedienungsanleitung / Operating Instructions / Instructions de Service / Manual de Instrucciones / Manuale di Istruzioni / 操作使用说明书. Includes a disclaimer and Japanese/Chinese text.

FCC Compliance section detailing regulatory requirements for the device's operation and interference.

Industry Canada Compliance section detailing regulatory requirements for the device's operation.

Additional regulatory information including Mexico and Korea compliance details.